

BLAZE

PowerZone
— Connect Series —



PRODUCT DESCRIPTION

The PowerZone Connect series of full matrix DSP amplifiers are designed to make life easier.

These smart amplifiers are configured in minutes, with our intuitive browser-based web app. From this simple interface, you can control the audio system from any device, on any platform, and handle all input, output, and multi-zone speaker management.

The ultra-compact size, and flexible power to channel set up, means PowerZone Connect is a perfect choice for many commercial audio projects. Then, using the digital output, expand any system by 'daisy-chaining' multiple amplifiers.

With the smart PowerZone Connect DSP amplifiers, you can set up and configure any system using our smart web app on your phone, tablet, or desktop.

- Product description 3
- Key Features 4
- PowerZone Control 4
- Solutions 5
 - Bars and Cafes
 - Restaurants
 - Retail stores
 - Fitness Centres
 - Hotels and Education Sites
 - Corporate/ Enterprise
 - House of Worship
- Front and Back Panel 6
- Technical Specifications 7
- Dimensions 8
- Accessories 8





KEY FEATURES

- A series of smart **full matrix DSP** amplifiers with complete configuration via the intuitive web app – you can simply set up everything from your phone.
- Connect to the system with **PowerZone Control** – configure the complete system - input sources & output channels, set up sound Zones, EQ, routing and much more.
- Optimal hybrid power performance of **both Lo-Z (4/8 ohm) and Hi-Z (constant voltage)** meaning one flexible PowerZone Connect amplifier can be used in many different configurations and set-ups.
- Total amplifier **power is shared** across output channels so you can utilize power where its needed.
- **GPIO interface** enables adding of any standard remote control (potentiometer) to your system
- **Link multiple amps** – via S/PDIF (Master /Slave)
- The PowerZone Connect series delivers class-leading energy efficiency reducing lifetime cost of ownership.
- **Ultra-compact** ½ rack form factor. Rack & wall mount kits means it can be **installed** where other brands cannot.
- Pascal's UMAC Class D amplifier technology is inside, with market proven, **ultra-reliable** U-PRO amplifier modules.

POWERZONE CONTROL

You can set up and control any PowerZone Connect DSP amplifier using your phone, tablet, or PC with the smart PowerZone Control Web App.

System integrators now have the freedom to manage even the most complex install projects with our dedicated PowerZone Control web app. Configure everything from your phone, or any other device of your choice. Simply connect through the amplifier's built-in Wi-Fi, or direct via the network port.

PowerZone Control makes life easier - thanks to its intuitive interface giving access first to the basic system set up, and then the advanced configuration and professional tuning settings. It allows you to create the most impressive multi-zone sound system, in the least amount of time.

The main dashboard shows a simple overview of your system, where volume levels are easily adjusted for each zone. Its effortless to set up and manage sound zones, pair inputs and outputs, and manage external volume controllers via the GPIO settings.

Explore a variety of advanced tuning options including delay settings, speaker EQ, Lo-Z and Hi-Z, and various other output options. Then via settings you have system and device info, built-in power management and the option of updating, saving, and exporting your amplifier's customized set-up as a profile you can restore or use on the next install project.

Make life easy and configure audio systems from your phone - with the PowerZone Connect and Control.

SOLUTIONS



Bars and Cafes

The combination of small size and big power flexibility makes PowerZone a great choice for installing in Bars and Cafés. Any system can be easily configured to cover exceptional background sound in locations with single or multiple zones.

Restaurants

Restaurant's use music as part of the dining experience which brings a dynamic sound need. Bar areas demand high sound pressure, and eating areas need much less. PowerZone is ideal and delivers the power required, to any channel, to any zone and to rooms of any size.



Retail stores

Background music in retail stores must complement the store's profile. This leads to a wide range of system demands. Some stores need cool background sound when others need for more power! PowerZone fit all these needs – and sound zones can be set up easily and power utilised where needed.

Fitness Centres

Fitness locations demand excellent sound with great system flexibility. Background tracks play in gym and workout areas - then heart racing power in the CrossFit classes! PowerZone can cope with these demanding environments as automatic power sharing delivers the required power across any channel and loudspeaker set up.

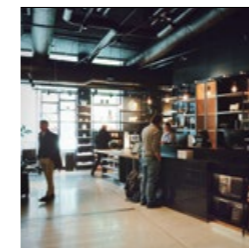
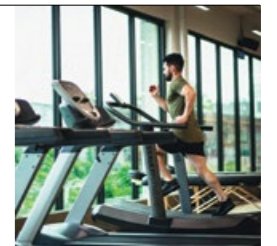

Hotels and Education Sites

For larger installations in hotels and educational facilities with auditoriums, theatres, vast eating spaces, and multiple large meeting rooms, complete power and system flexibility is required. With PowerZone amplifiers you simply match the power and channels you need – then easily configure the system for all the different sound needs.

Corporate/ Enterprise

The corporate space has many different applications – open office spaces, sound for boardrooms and conference rooms, meeting areas of any size – plus warehouses, cafeteria and break areas. PowerZone is an ideal choice as one amplifier can cover all the sound needs.

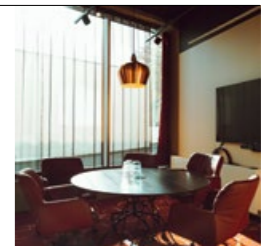

House of Worship

House of Worship sites need very reliable, high-quality amplification of voice, and at the same time the amplifier should cover a large distribution area with many specialized speakers. PowerZone are perfect for house of worship sites – due to the high quality of amplification at low power, delivering superior speech intelligibility.

FRONT AND BACK PANEL



1. **Intuitive LED Guide** - Status, Input, Output, Networked or Wi-Fi
2. **RJ45 connection** - Direct Network access
3. **Wall control input** - Mute/Std +more - Selectable in Control SW
4. **Wi-Fi antenna**
5. **Digital audio in/out**
6. **4 x Unbalanced RCA input**
7. **Balanced inputs** - Mic input on CH1 and CH2 - Sensitivity selectable in Control SW
8. **4 x Lo-Z outputs or 2 x Hi-Z outputs**
9. **Mains Power** IEC 90-268Vac input

*Product shown as example is PowerZone Connect 4 Channel version (504) also available in 2 Channel versions

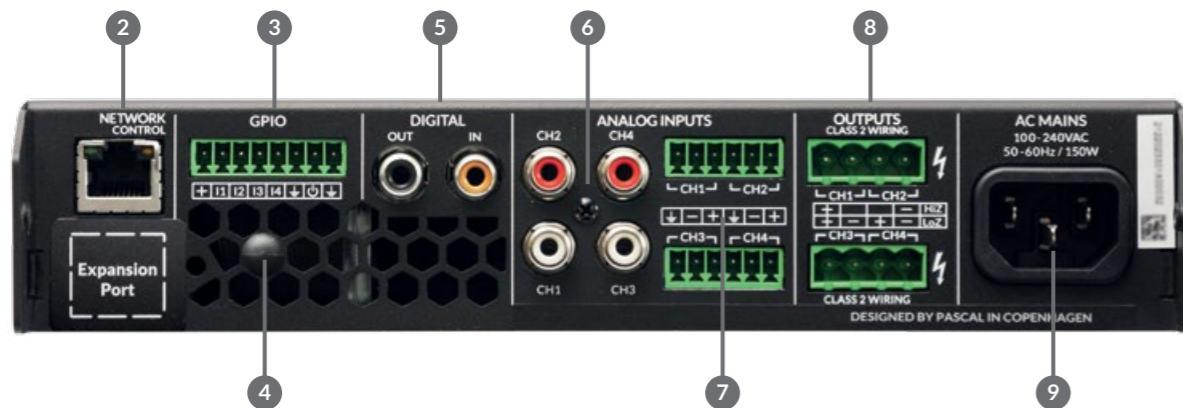

TECHNICAL SPECIFICATIONS

Model	PowerZone Connect 122	PowerZone Connect 252	PowerZone Connect 254	PowerZone Connect 504
Total System Power	125 W	250 W	250 W	500 W
Output Power @ 4/8Ω	2 x 60 W	2 x 125 W	4 x 60 W	4 x 125 W
Output Power @ 70/100V*	1 x 125 W	1 x 250 W	2 x 125 W	2 x 250 W
Powershare (up to) Across all channels**	1 x 125 W	1 x 250 W	1 x 250 W	2 x 250 W
Power Consumption	75W	75W	75W	150W
Dimensions	44 x 220 x 213 mm (1.7 x 8.7 x 8.4 in)	44 x 220 x 213 mm (1.7 x 8.7 x 8.4 in)	44 x 220 x 319 mm (1.7 x 8.7 x 12.6 in)	44 x 220 x 319 mm (1.7 x 8.7 x 12.6 in)
Weight	2kg (4.4 lbs)	2kg (4.4 lbs)	2.8kg (6.2 lbs)	2.8kg (6.2 lbs)
Output Circuitry	UMAC™ Class D - full bandwidth PWM modulator with ultra-low distortion			
Output Voltage	70Vp / 140Vpp (unloaded) // Bridged 140Vp / 280 Vpp (unloaded)			
Signal To Noise-Ratio	>106dB (A-weighted, 20Hz-20kHz, 8Ω load)			
THD+N (typical)	< 0.05% (20Hz-20kHz, 8Ω load, 3dB below rated power)			
Frequency Response	20Hz-20kHz (+0/-0.25dB (8Ω load, 3dB below rated power)			
Protection Circuits	Short circuit -, DC -, Undervoltage -, Temperature - and Overload protection			
Power Supply	UREC™ universal mains switch mode power supply with Power Factor Correction (PFC) and standby converter			
Operating temperature	0-40°C			
Operating Voltage/ Frequency	Universal Mains, 100V-240V, 50Hz-60Hz			
Standby Consumption	< 0.5W			
Accessories	2x Rack ears 1x ½ rack plate extension 2x ½ rack mounting 2x Rear supports			
Power Ratings	1% THD @ 120Vac and 230Vac			

*100V line mode is @ -1dB (= 90 V)

**504 may only Powershare across Ch1/2 and Ch3/4

BLAZE

DIMENSIONS

PowerZone Connect 122 & 252

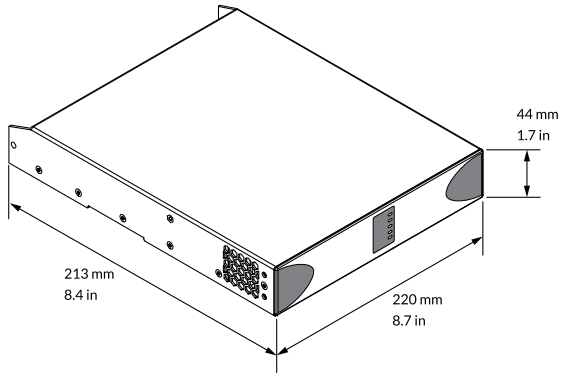

PowerZone Connect 254 & 504

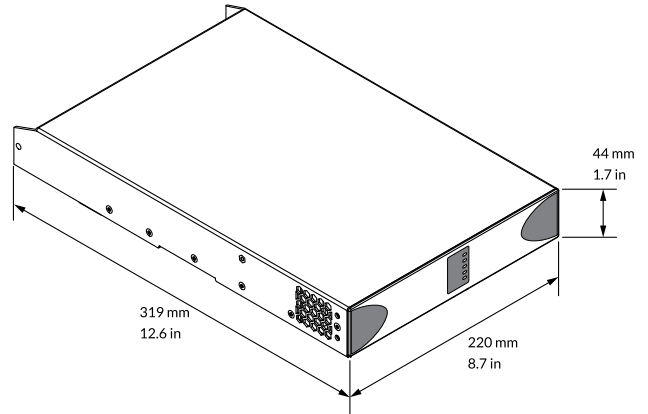

ACCESSORIES

